



DURATION WINDOWS

Hinged Secondary Glazing Luxury Subframe System Section Identification

Contents

● Section Identification Overview		Page 2
● Outerframe		Page 3
● Hinged Panels		Page 4
● Locking Catch & Hinges		Page 5
● Subframes		Page 6
● Single Butt Hinged	- SF1 Cross Section	Page 7
	- SF1 Plan View	Page 8
	- SF3 Cross Section	Page 9
	- SF3 Plan View	Page 10
● Double Butt Hinged	- SF1 Cross Section	Page 11
	- SF1 Plan View	Page 12
	- SF3 Cross Section	Page 13
	- SF3 Plan View	Page 14
● Friction Hinged (Side Hung)	- SF1 Cross Section	Page 15
	- SF1 Plan View	Page 16
	- SF3 Cross Section	Page 17
	- SF3 Plan View	Page 18
● Friction Hinged (Top Hung)	- SF1 Cross Section	Page 19
	- SF1 Plan View	Page 20
	- SF3 Cross Section	Page 21
	- SF3 Plan View	Page 22

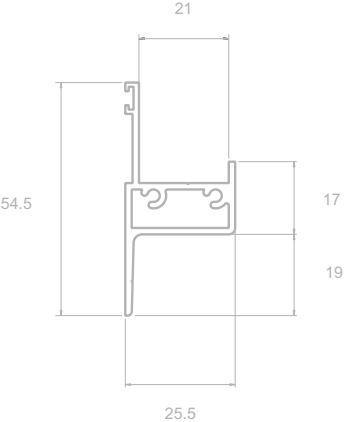
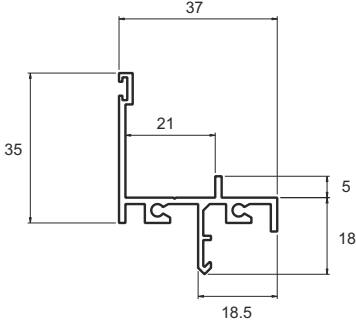
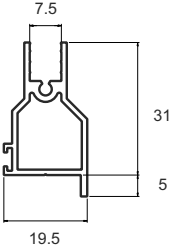
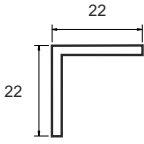
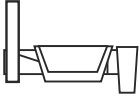
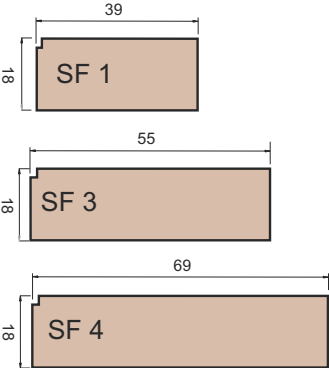
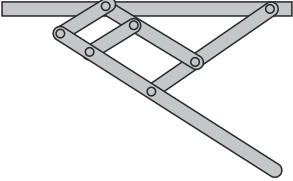
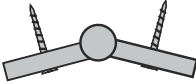

Overview

<p>Economy Outerframe</p>	<p>Subframe Outerframe</p>
<p>SG 93 Odd Leg Outerframe with screw ports</p> 	<p>SG 70 Subframe Fix Outerframe with screw ports</p> 
<p>Hinged Sash And Interlocks</p>	<p>Locking Catch</p>
<p>SG 69 Hinged Sash with screw ports</p>  <p>SG L1 Meeting Stile Interlock</p> 	<p>Locking Catch</p> 
<p>Subframes</p>	<p>Hinges</p>
	<p>Friction Hinges</p>  <p>Butt Hinges</p> 

* Please Note: greyed out parts are not applicable the Luxury Subframe system.



Outerframe

SG 70
Odd Leg Outerframe
with screw ports

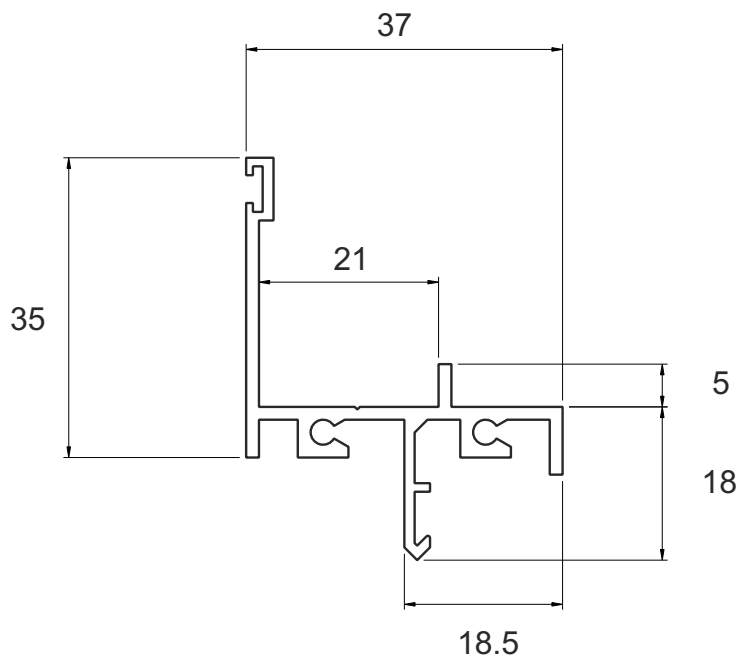



Hinged Sashes

SG 69
Hinged Sash
with screw ports

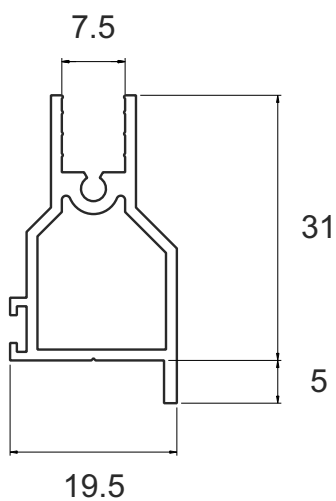

SG L1
Meeting Stile Interlock

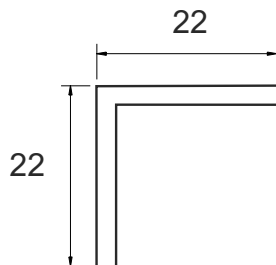



Locking Catch

Locking Catch

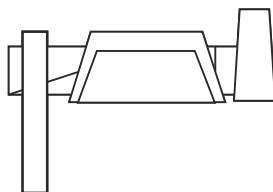

Hinges

Friction Hinge

Max. Opening Angle

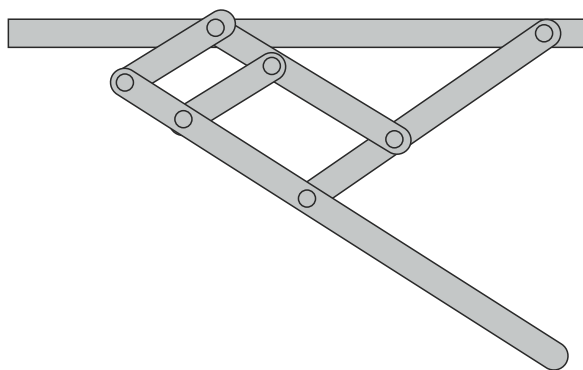
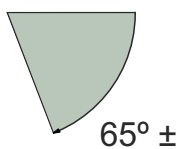

Butt Hinge

Max. Opening Angle

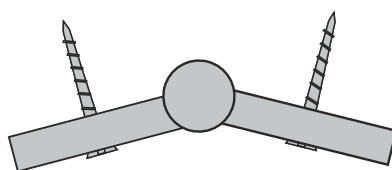
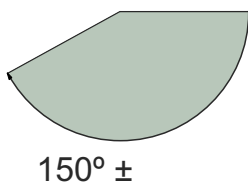



Subframes

SF 1

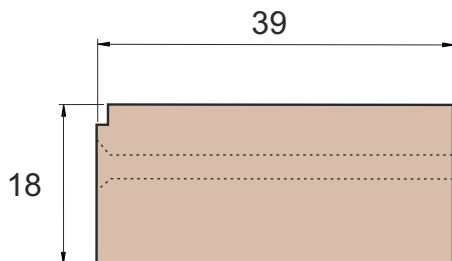

SF1 comes with
pre-drilled fixing holes
as standard

SF 3

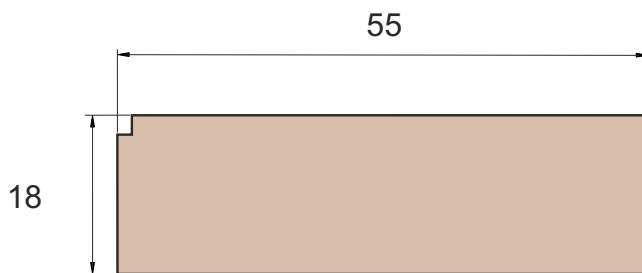

If you require
pre-drilled fixing holes
in your SF3
Please ask.

SF 4

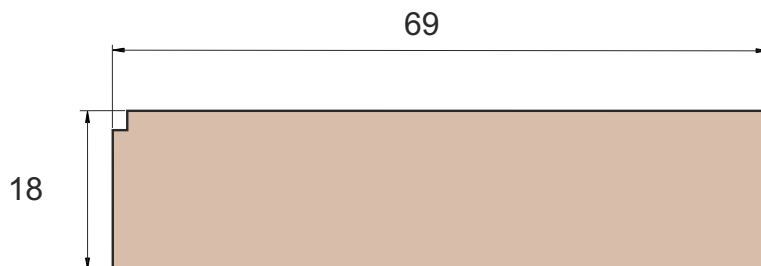

If you require
pre-drilled fixing
holes in your SF4
Please ask.

Single Butt Hinged - SF1 - Plan View

Luxury Subframe - SF1 Face Fix

B - Left Jamb

C - Right Jamb

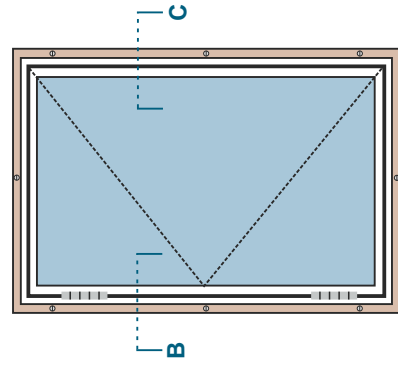
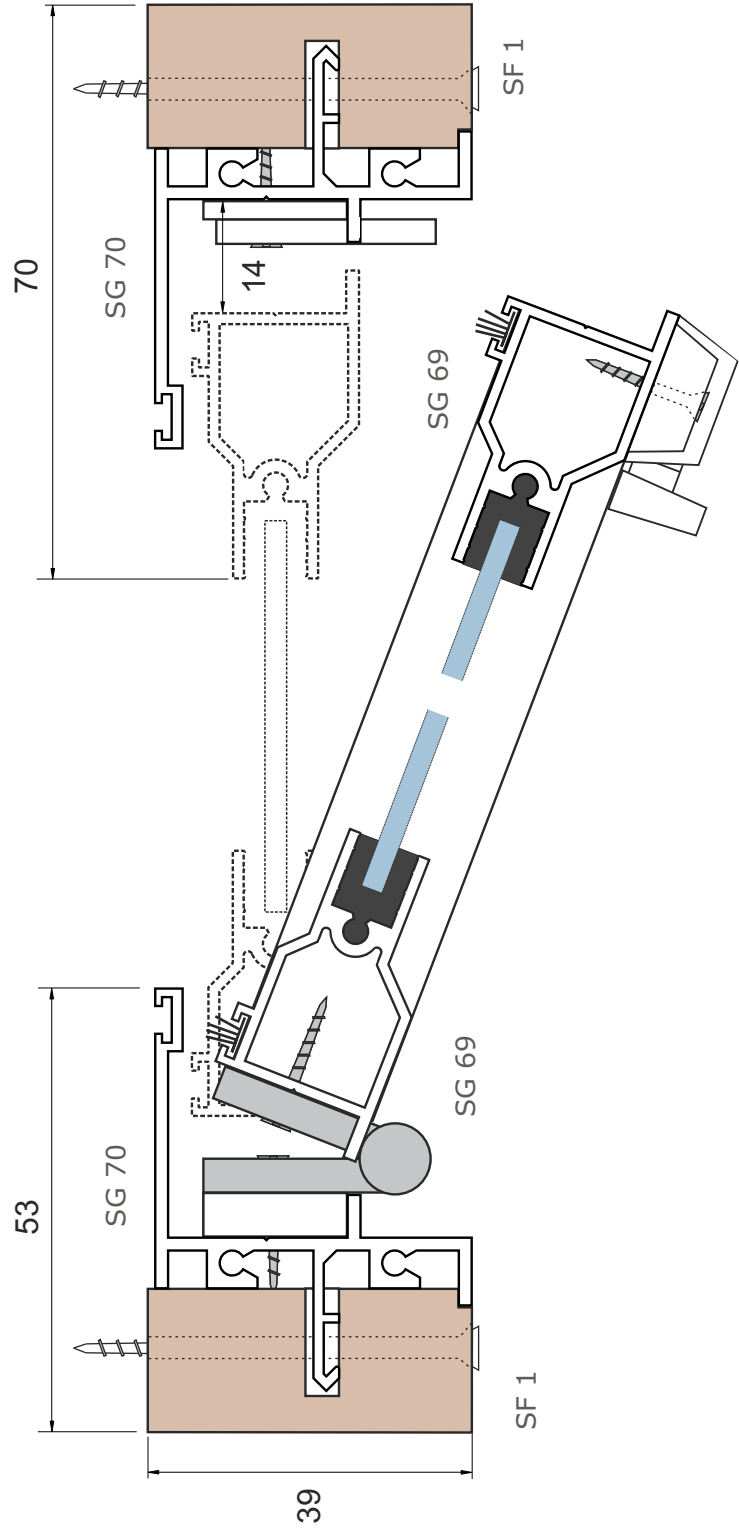

Max. Opening Angle

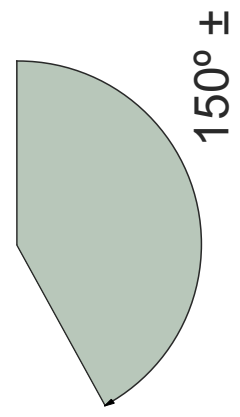



Single Butt Hinged - SF3 - Cross Section

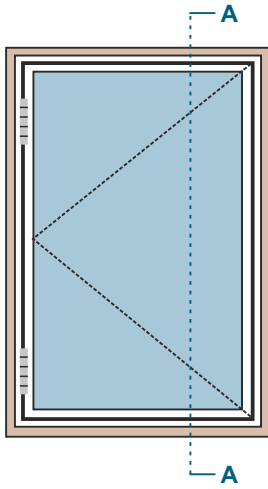

Luxury Subframe - SF3 Reveal Fix

A - Cross Section

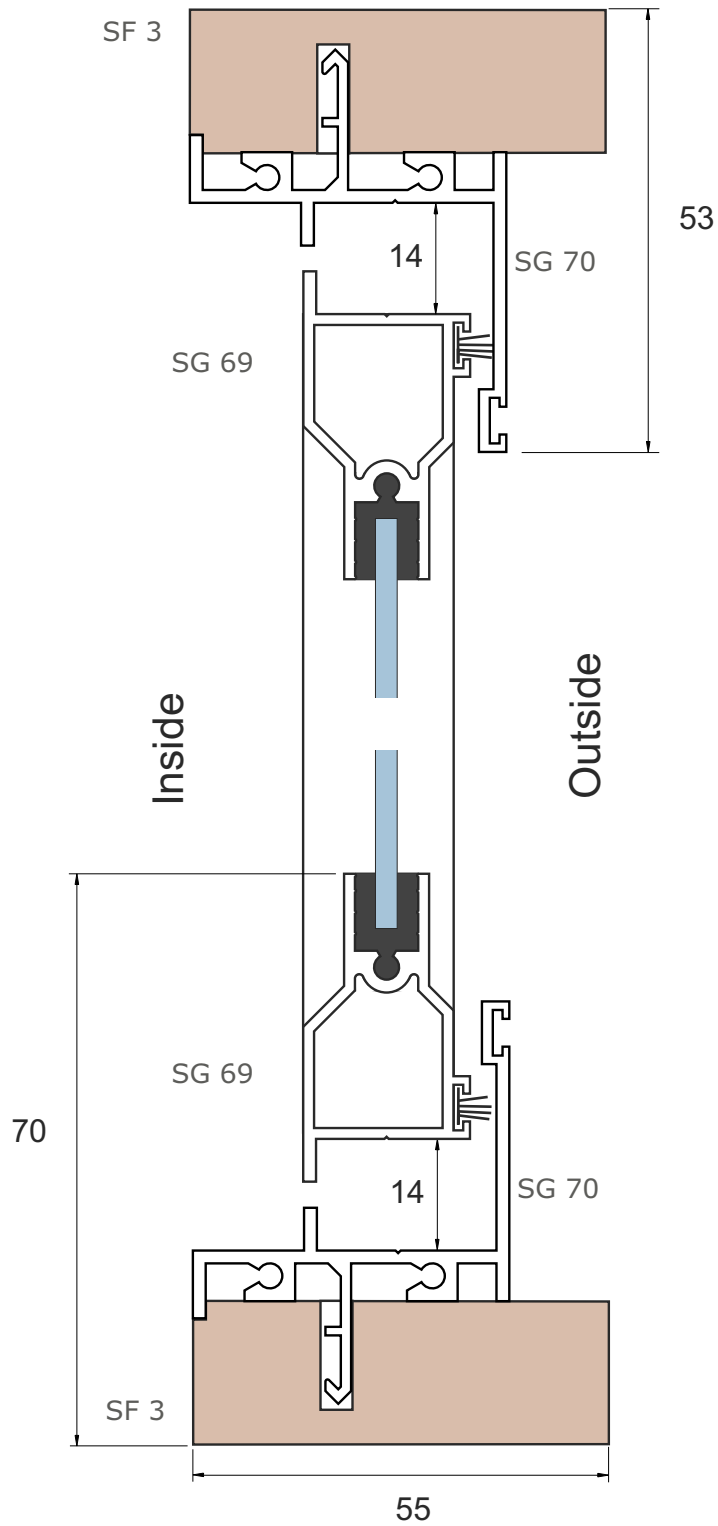

Single Butt Hinged - SF3 - Plan View

Luxury Subframe - SF3 Reveal Fix

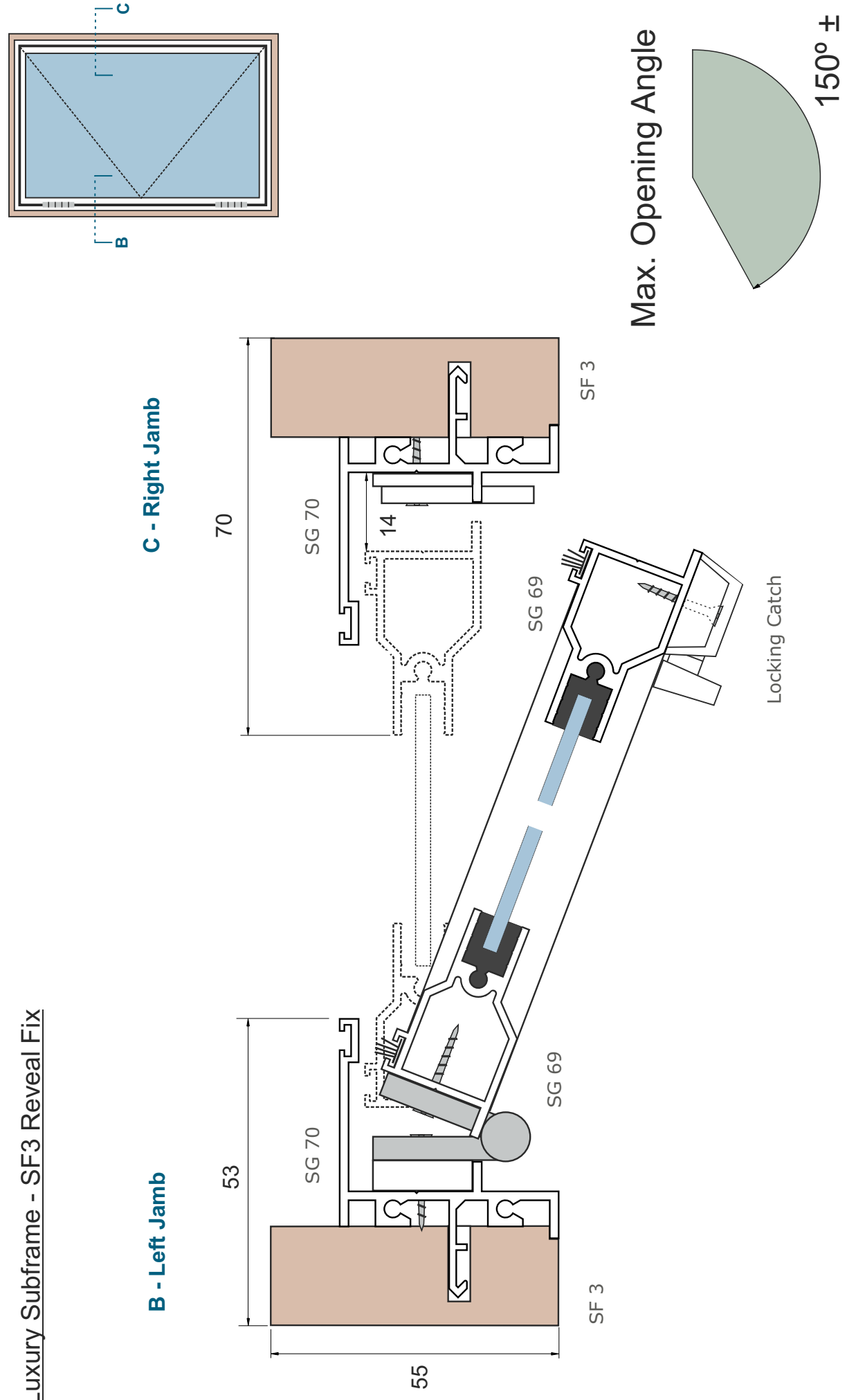

B - Left Jamb

C - Right Jamb

Max. Opening Angle

150° ±

Locking Catch



Double Butt Hinged - SF1 - Cross Section

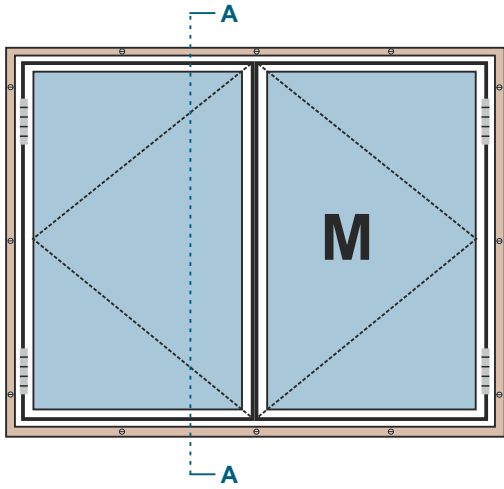

M - This indicates the master panel. The other panel is therefore the slave panel.

Luxury Subframe - SF1 Face Fix

A - Cross Section

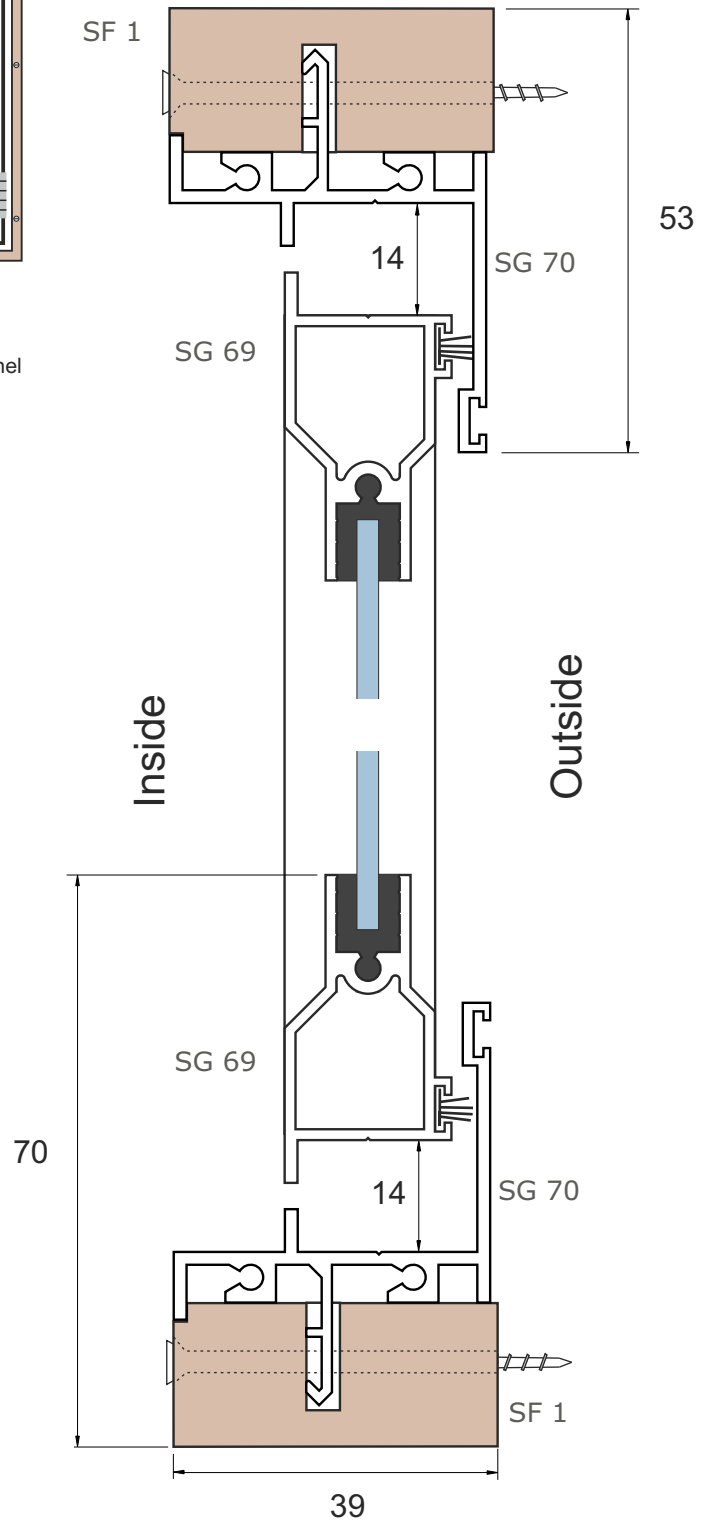

Double Butt Hinged - SF1 - Plan View

Luxury Subframe - SF1 Face Fix

Max. Opening Angle

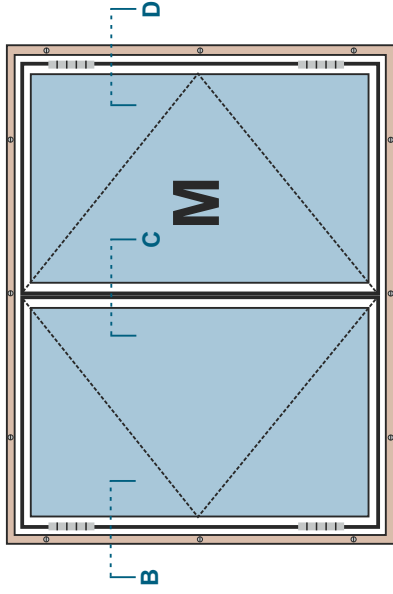
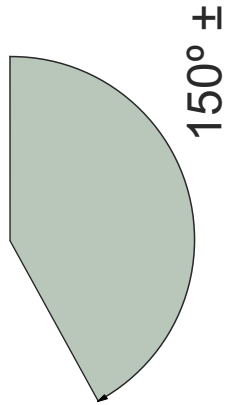

M - This indicates the master panel. The other panel is therefore the slave panel.

B - Left Jamb

C - Meeting Stiles

D - Right Jamb

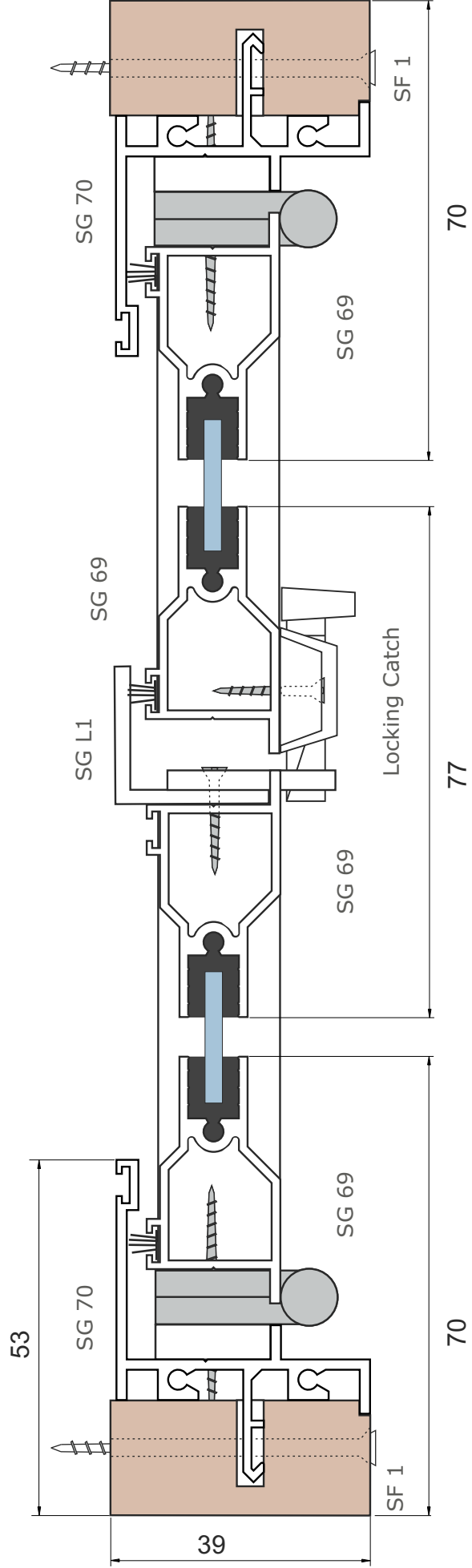



Double Butt Hinged - SF3 - Cross Section

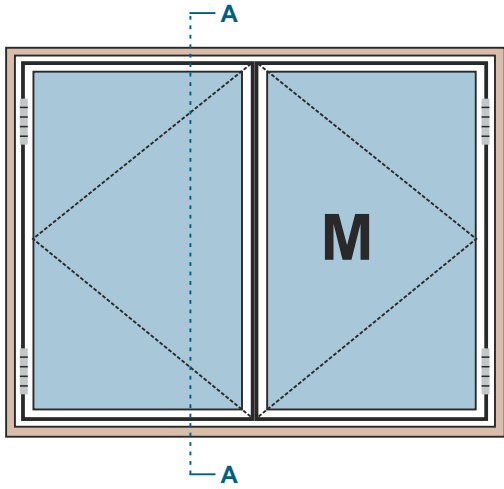

M - This indicates the master panel. The other panel is therefore the slave panel.

Luxury Subframe - SF3 Reveal Fix

A - Cross Section

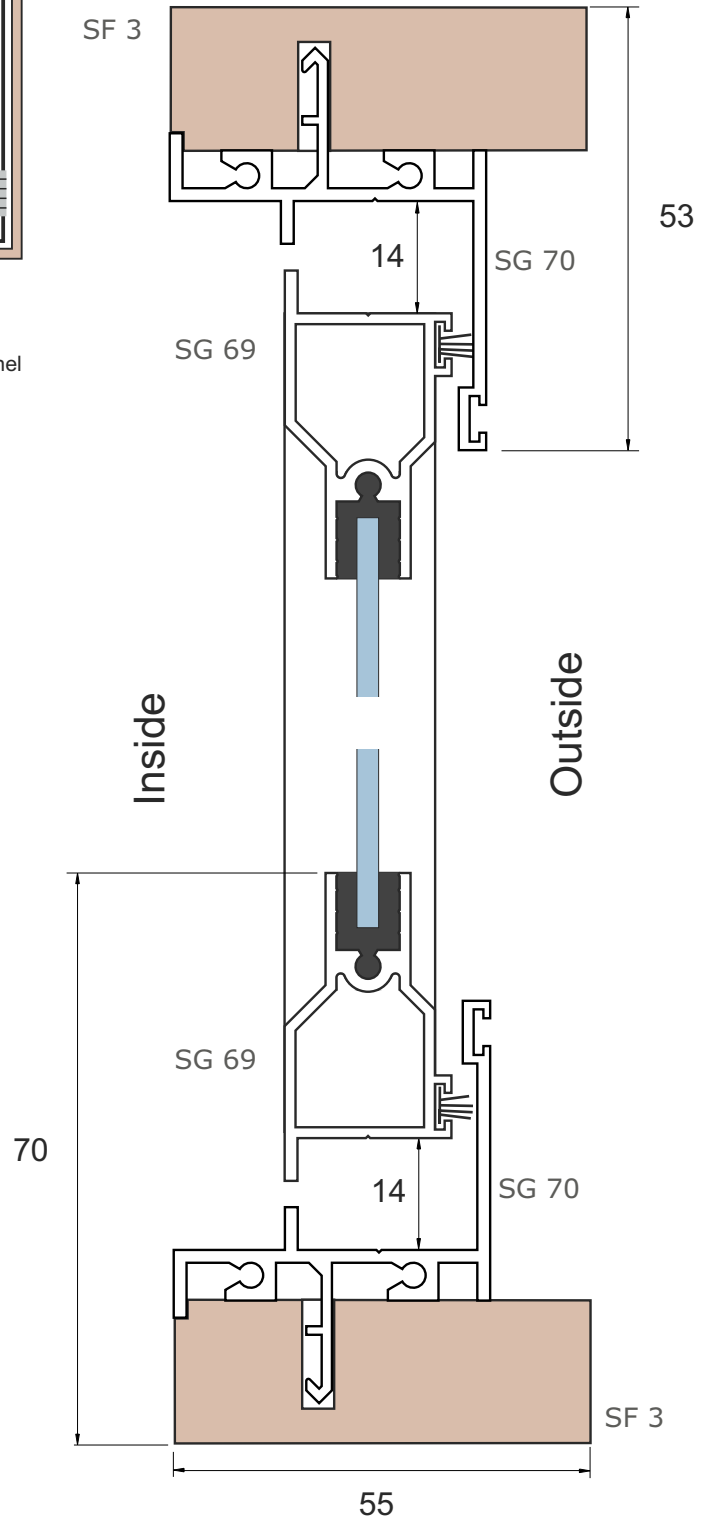

Double Butt Hinged - SF3 - Plan View

Luxury Subframe - SF3 Reveal Fix

Max. Opening Angle

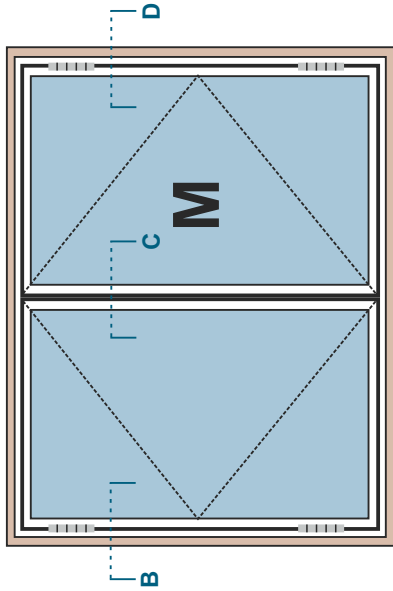
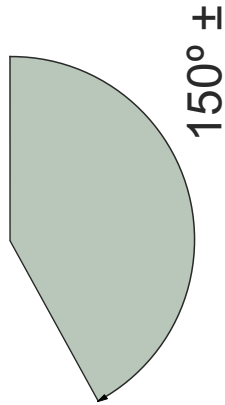

M - This indicates the master panel. The other panel is therefore the slave panel.

B - Left Jamb

C - Meeting Stiles

D - Right Jamb

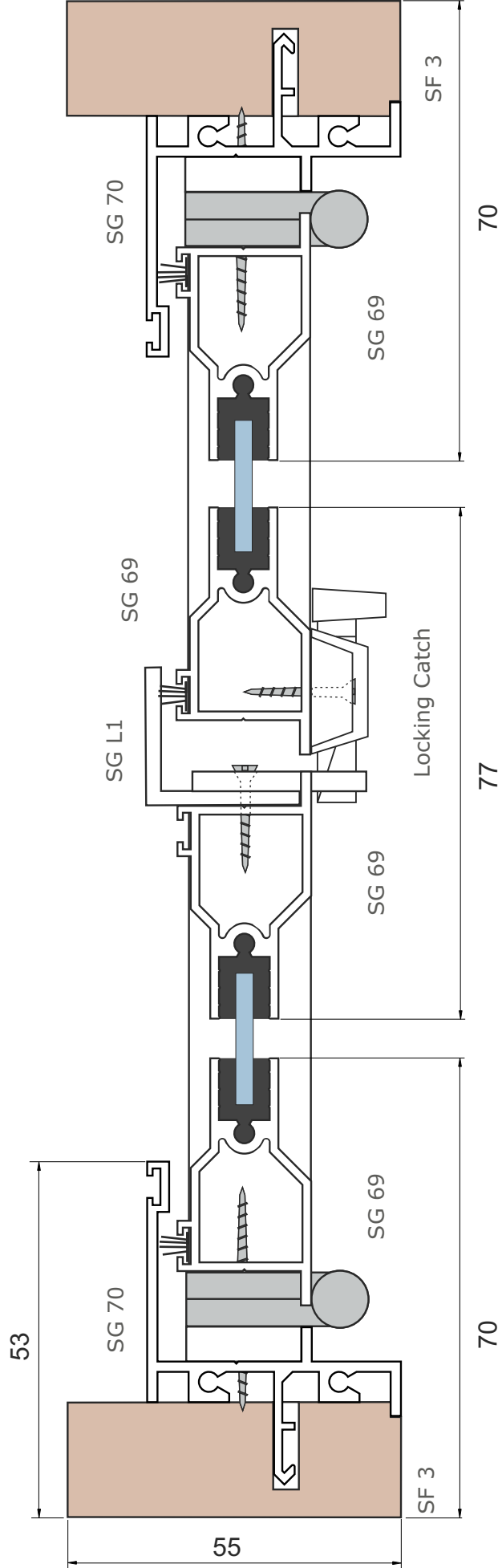



Friction Hinged - Side Hung - SF1 - Cross Section

Luxury Subframe - SF1 Face Fix

A - Cross Section

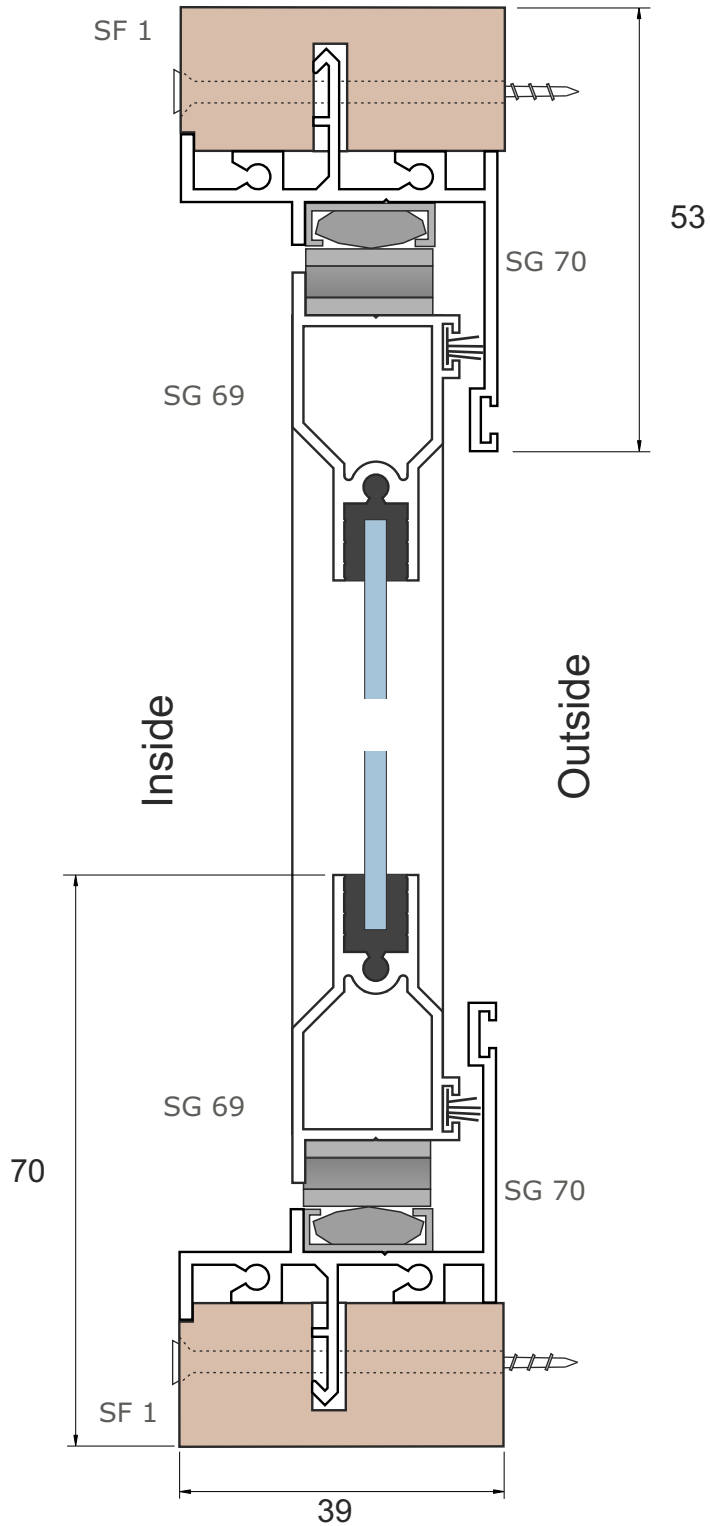
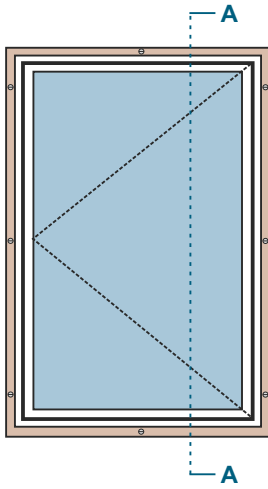

Friction Hinged - SF1 - Plan View

Luxury Subframe - SF1 Face Fix

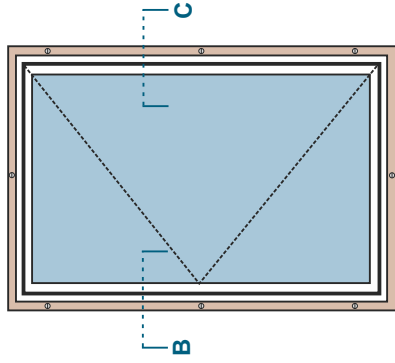

B - Left Jamb

B - Right Jamb

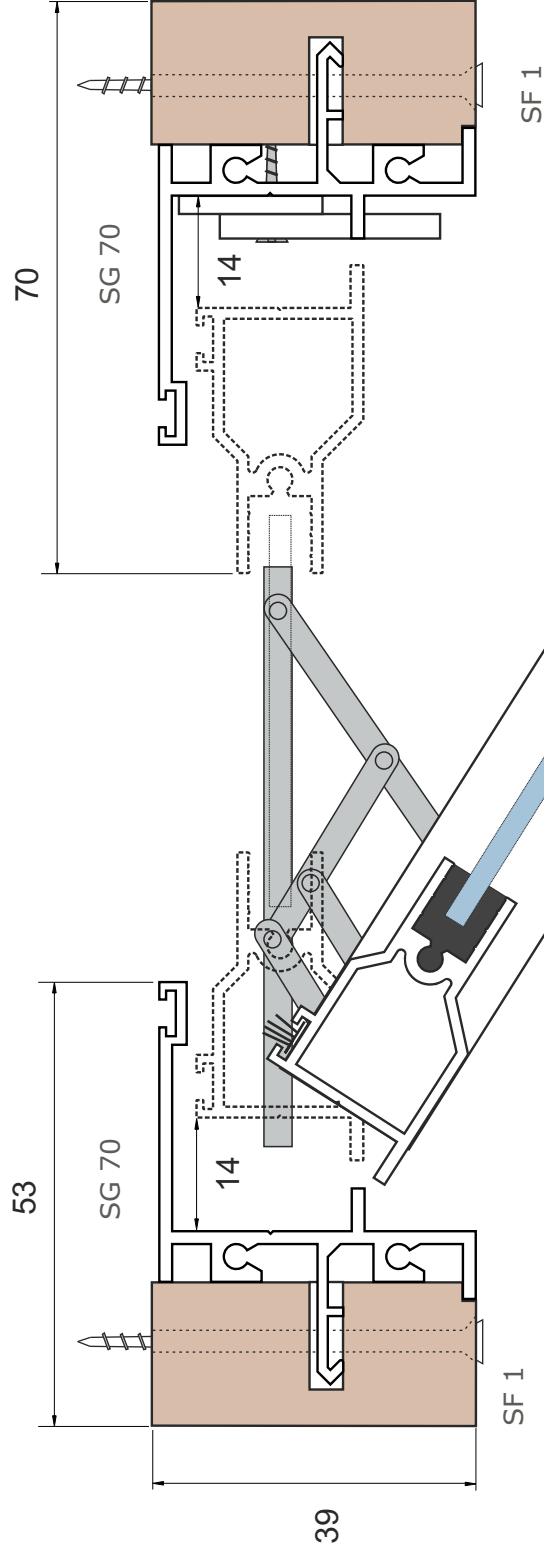

Max. Opening Angle

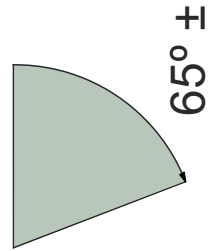



Friction Hinged - Side Hung - SF3 - Cross Section

Luxury Subframe - SF3 Reveal Fix

A - Cross Section

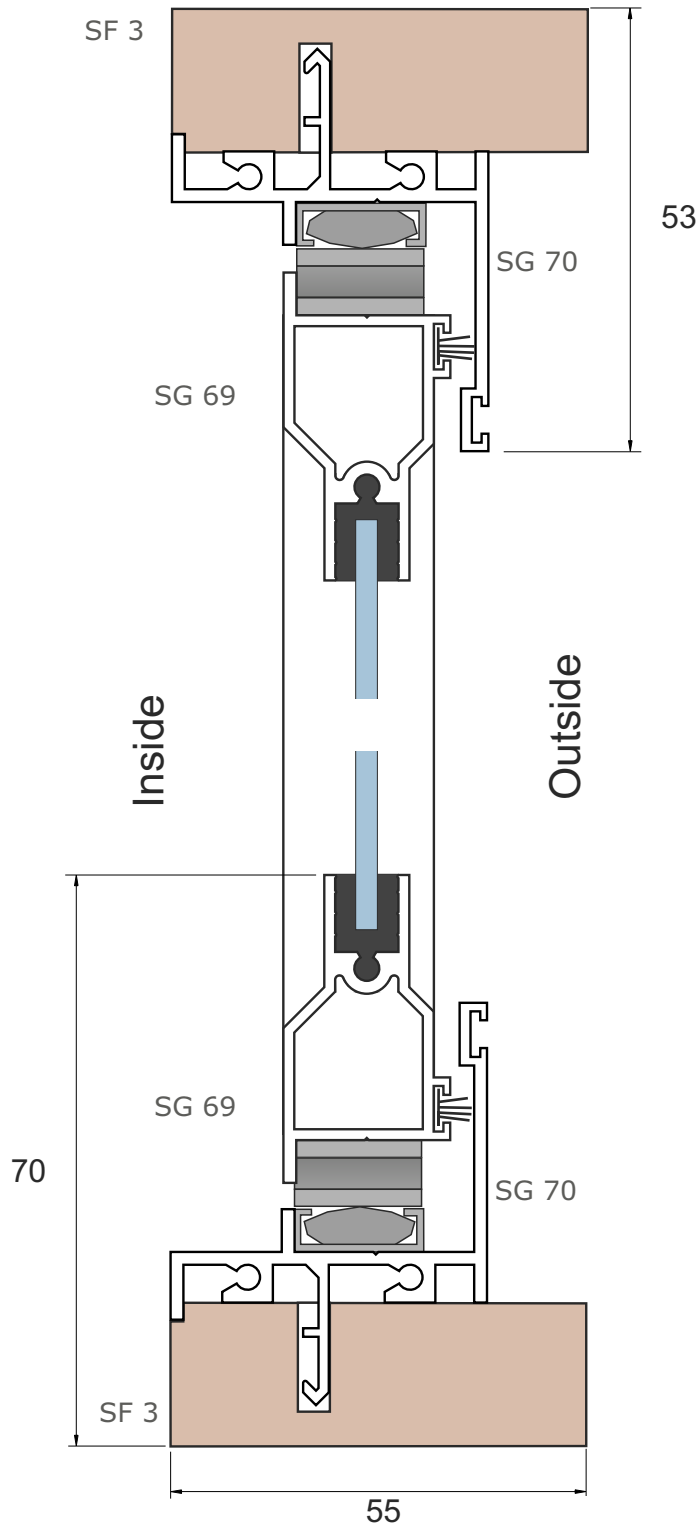
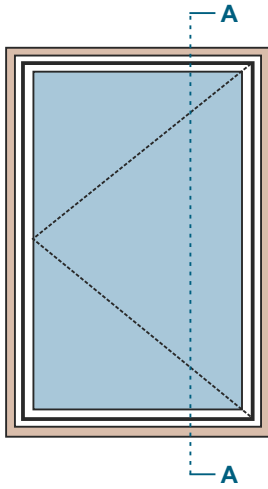

Friction Hinged - SF3 - Plan View

Luxury Subframe - SF3 Reveal Fix

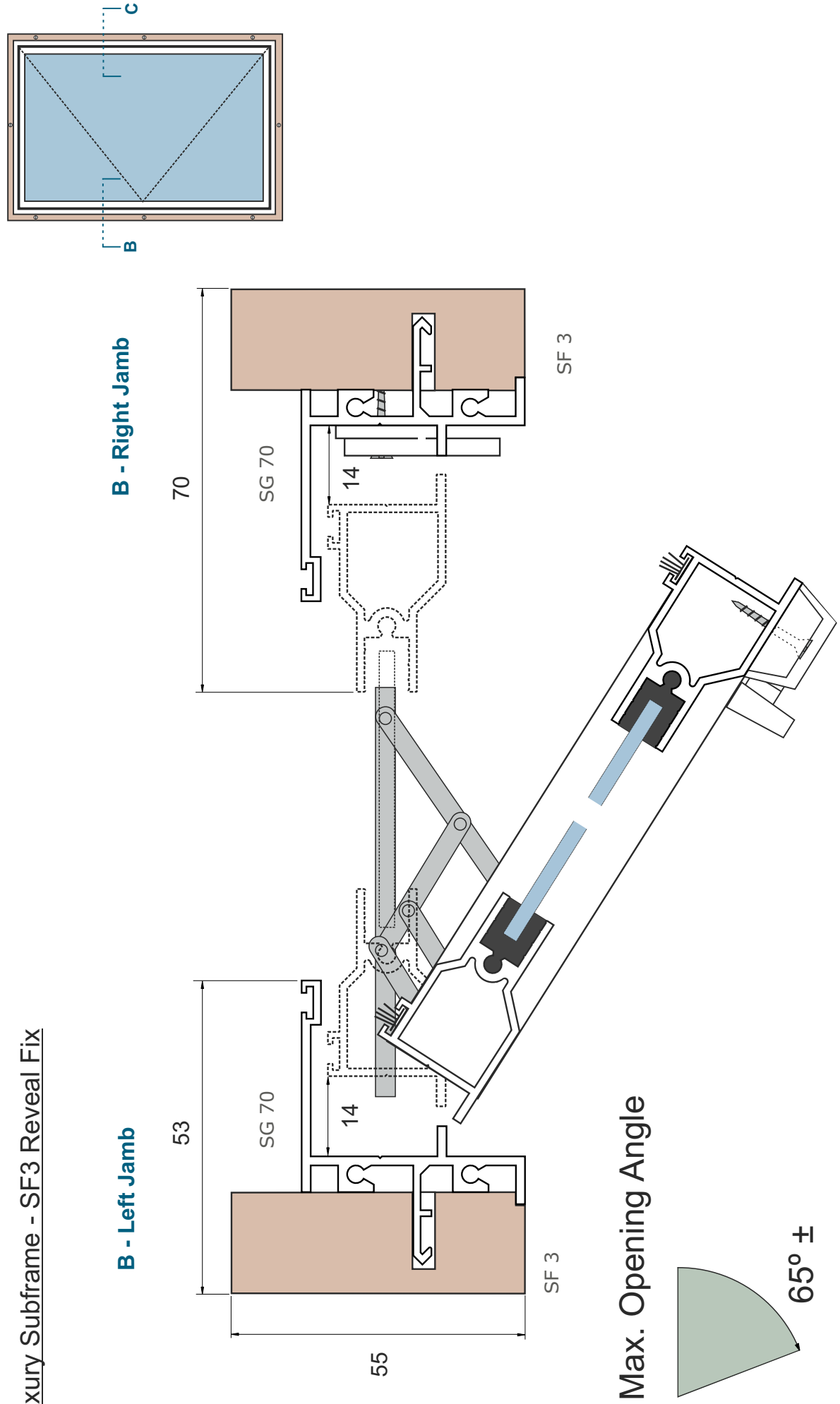



Single Butt Hinged - SF1 - Cross Section

Luxury Subframe - SF1 Face Fix

A - Cross Section

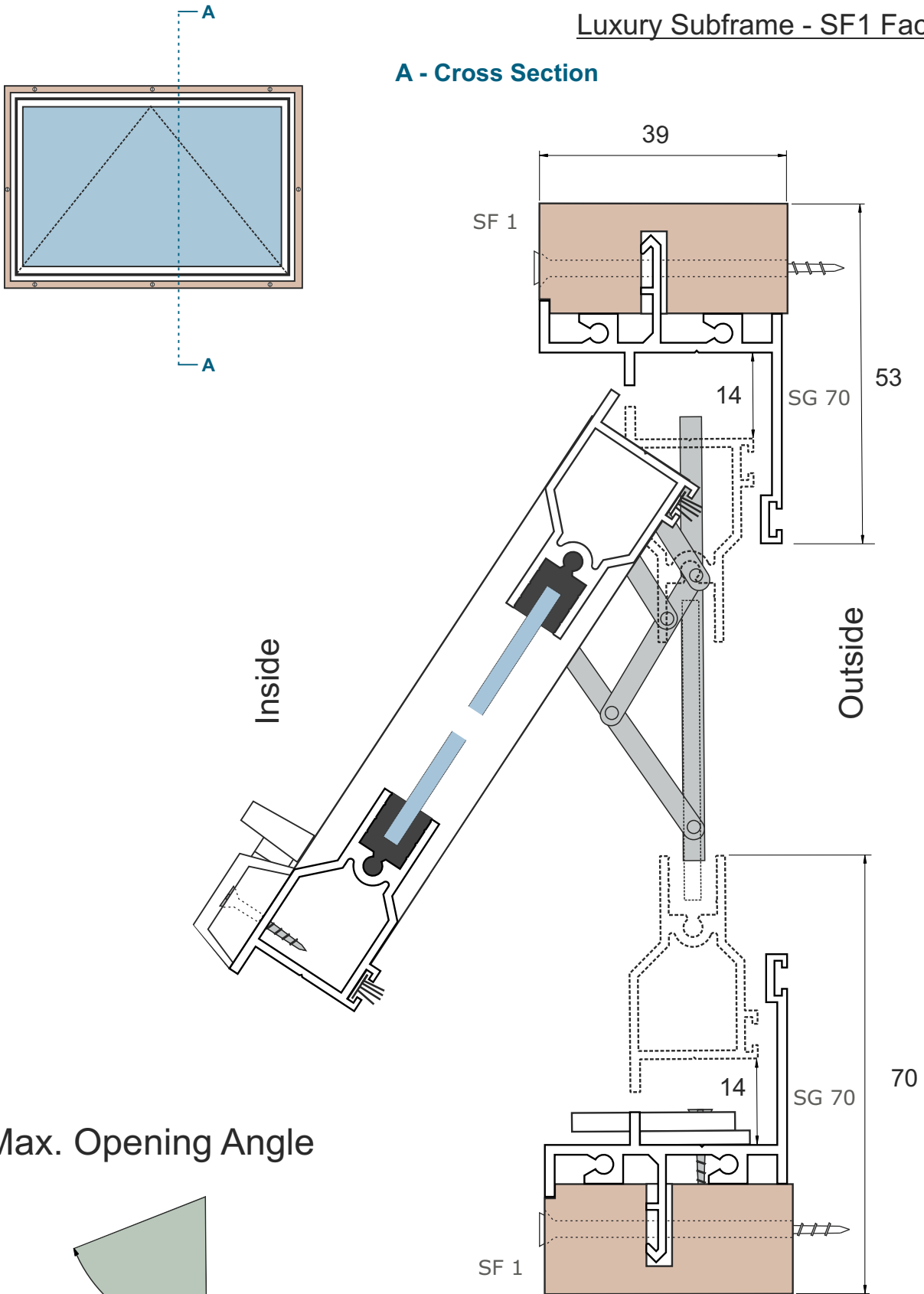

Max. Opening Angle

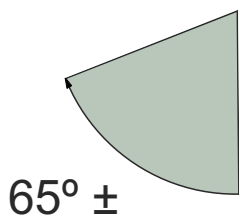

65° ±

Single Butt Hinged - SF1 - Plan View

Luxury Subframe - SF1 Face Fix

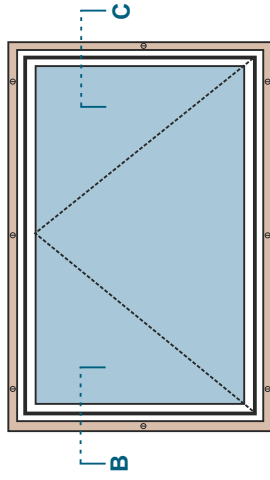

B - Left Jamb

C - Right Jamb

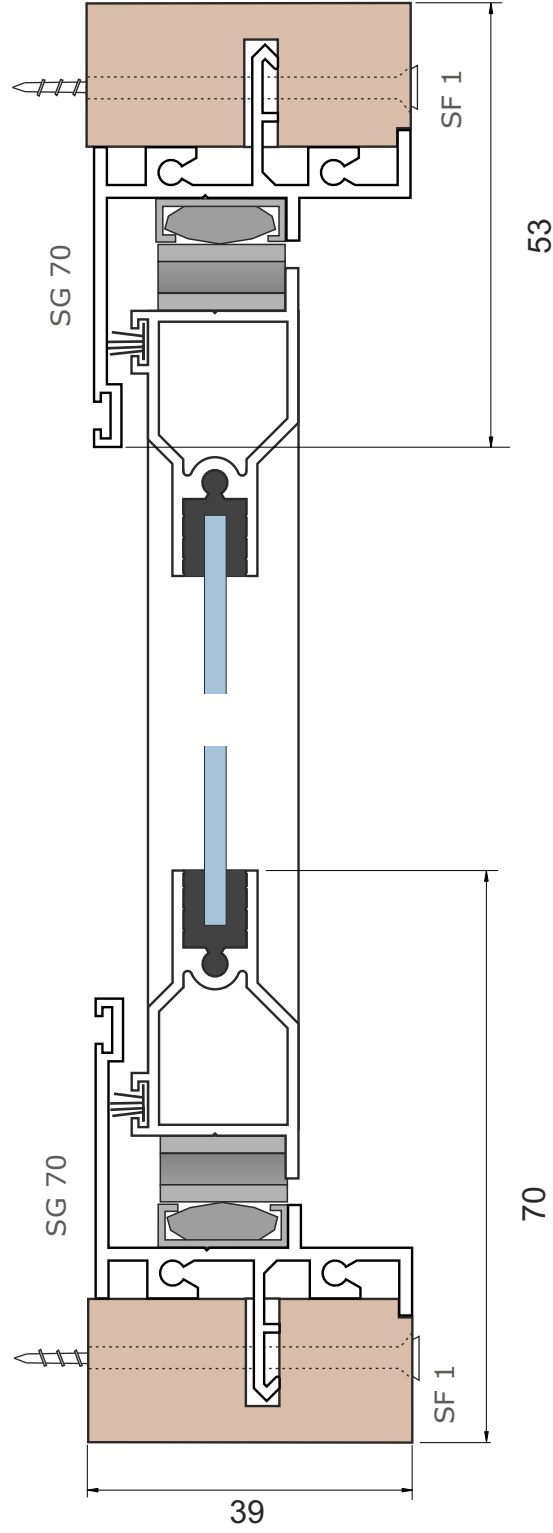



Single Butt Hinged - SF3 - Cross Section

Luxury Subframe - SF3 Reveal Fix

A - Cross Section

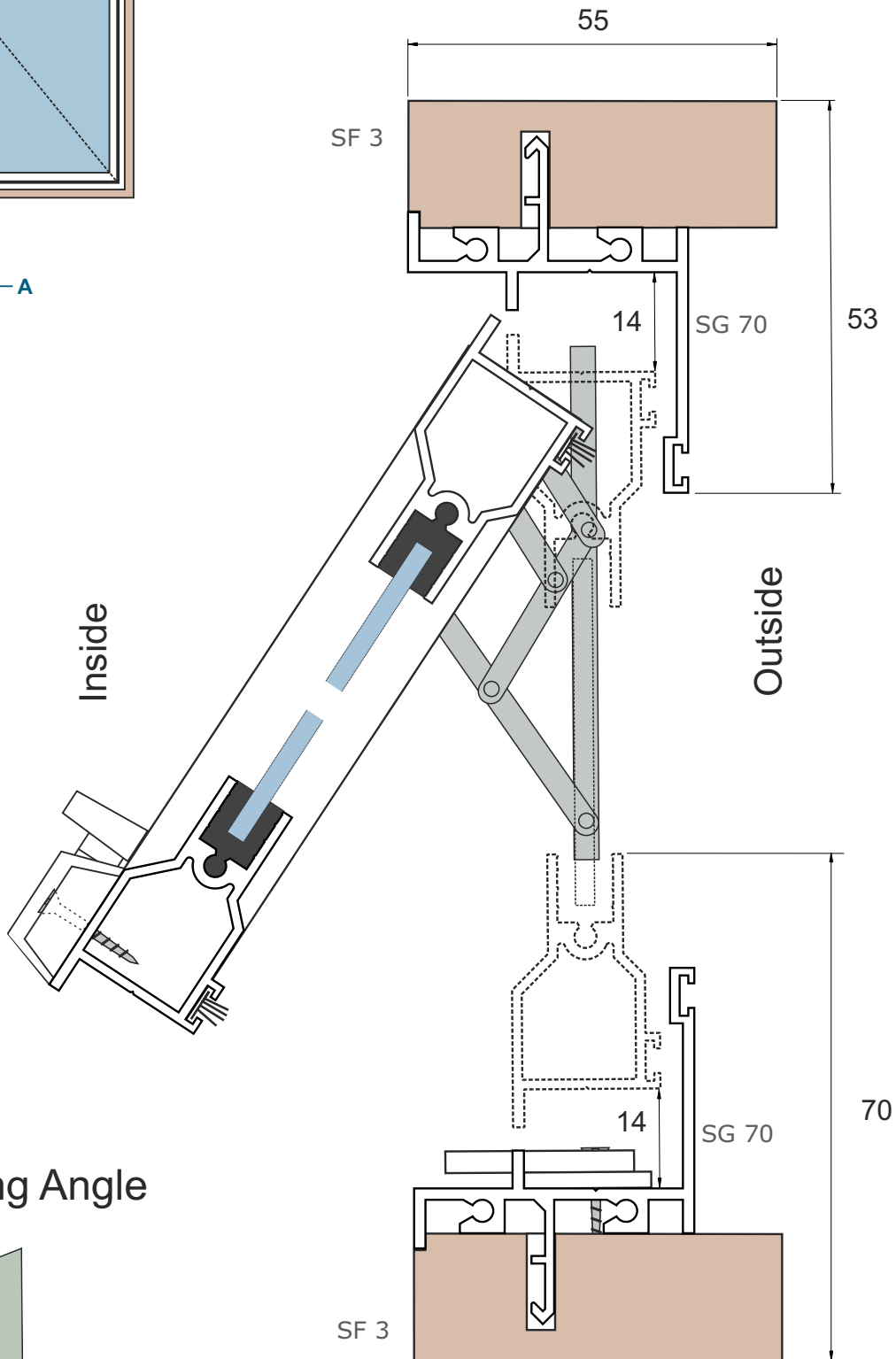
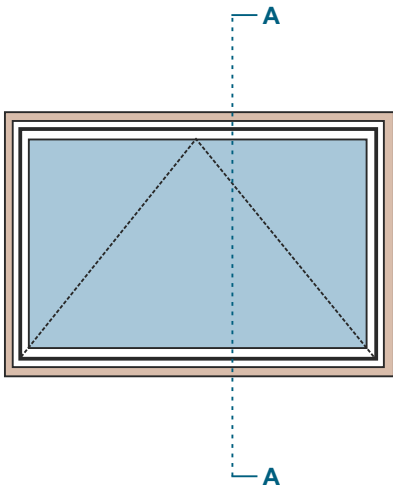

Max. Opening Angle

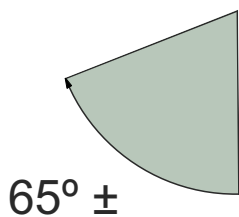

Single Butt Hinged - SF3 - Plan View

Luxury Subframe - SF3 Reveal Fix

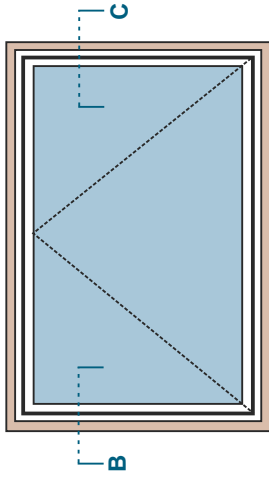

B - Left Jamb

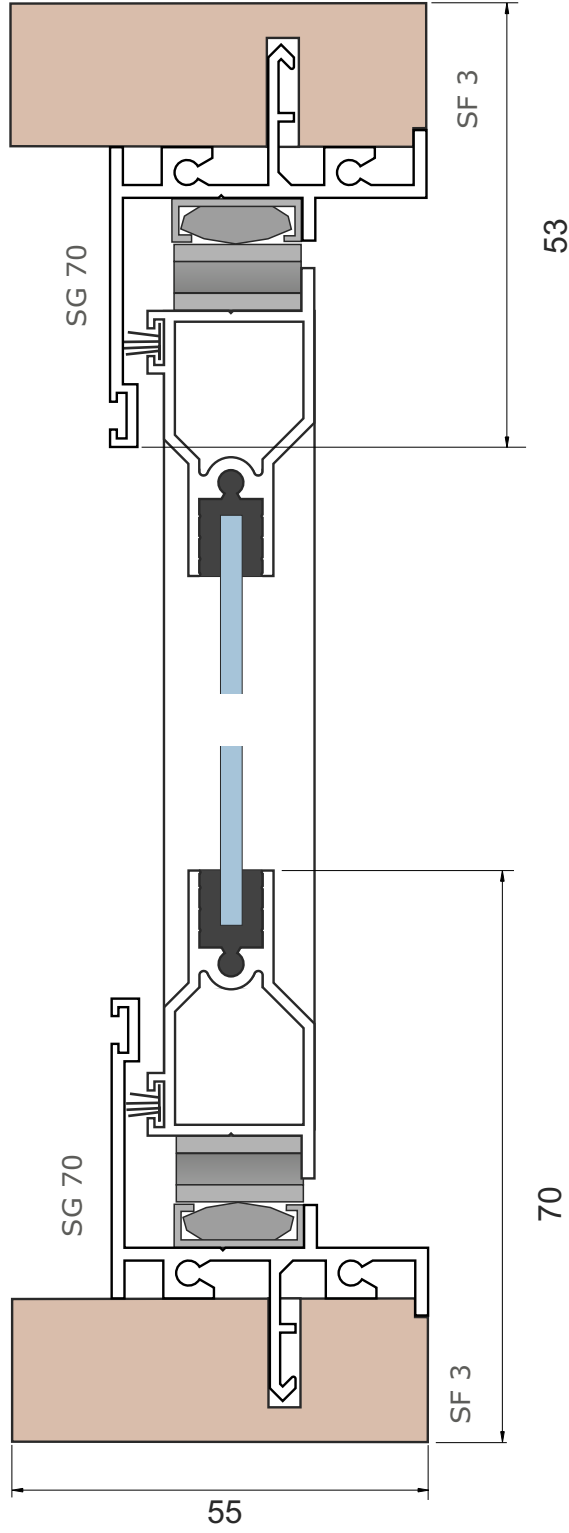

C - Right Jamb